

## FICHA DE PRODUCTO

## MULTISISTEMA

Unidad Lite



RG70E2(2)/BGEF

## CARACTERÍSTICAS

Modelo	MSMAFBU-09HRDN8-QRD0GW	MSMAFBU-12HRDN8-QRD0GW
Capacidad frigorífica	2,64 kW	3,52 kW
Capacidad calorífica	2,93 kW	3,81 kW
Tuberías frigoríficas Líquido - Gas	1/4" - 3/8"	1/4" - 3/8"
Caudal de aire	520/460/340 m <sup>3</sup> /h	600/500/360 m <sup>3</sup> /h
Presión sonora	19,5 dB(A)	21,5 dB(A)

## CONEXIÓN ELÉCTRICA

Modelo	MSMAFBU-09HRDN8-QRD0GW	MSMAFBU-12HRDN8-QRD0GW
Alimentación	220-240 V / 1 fase / 50 Hz	
Cable Alimentación	(3+Tierra) x 2,5 mm	

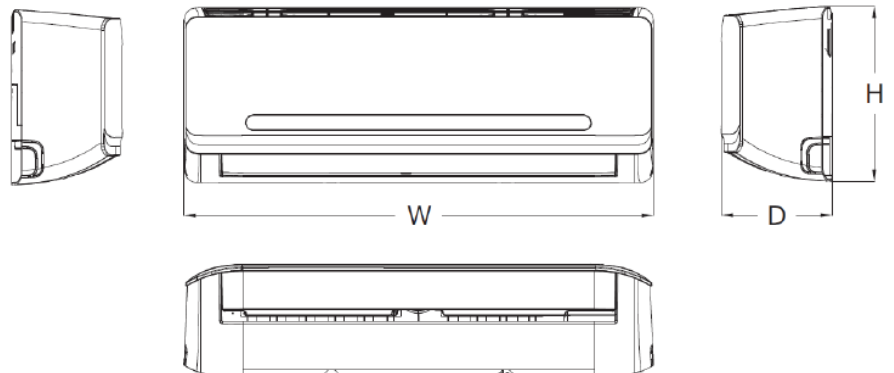
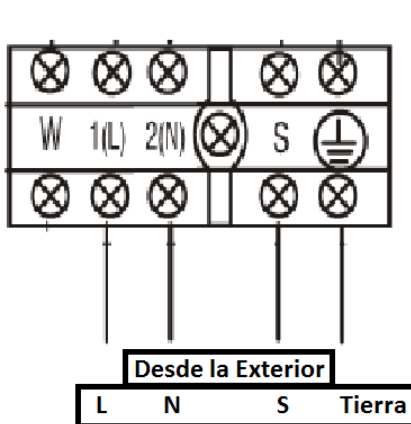

## DIMENSIONES Y PESO

Modelo	MSMAFBU-09HRDN8-QRD0GW	MSMAFBU-12HRDN8-QRD0GW
Ancho (W)	805 mm	805 mm
Alto (H)	285 mm	285 mm
Fondo (D)	205 mm	205 mm
Peso	7,9 kg	7,9 kg